

# EVA

## RATE CARD

### advertising formats (BGN before VAT)

#### PAGES

single right page	4200
1/2 right page	3200
1/3 right page	2200
1/4 right page	
(placed in index pages)	1200

- 10% for left pages

#### SPREADS

1st spread page	8200
leading spread page	6500
spread page	6100

#### COVERS

back cover	8200
3th cover	5000
2nd cover	6000
gatefold	12000

### discounts and overcharges

for advertising agencies	10%
for combination of titles	5%

#### VOLUME DISCOUNTS

2 - 5	13%
6 - 10	15%
11 - 16	20%
17 - 26	25%
27 - 36	30%
37 - 46	32%
47 - 60	34%

#### FOR INSERTS

-20% when combined with an ad page

#### OVERCHARGES

+20% for fixed page/rubric

### inserts and samples (BGN before VAT)

#### INSERTS\*

whole print run	0.20 lv./per copy
partly print run**	0.30 lv./per copy
sticked samples	+ 0.05 lv./per copy

\* leaflets and catalogues - up to 12 pages 12, size A5

\*\* minimum print run for insertion - 30% of the whole

#### deadlines

booking -  
up to 10th of the previous month  
receiving ad materials -  
up to 15th of the previous month

### additional info

MONTHLY PRINT RUN - 10 000  
DATE OF RELEASE - 10-15 date of each month  
NUMBER OF ISSUES PER YEAR - 12

# EVA

## TECHNICAL REQUIREMENTS

### advertising formats

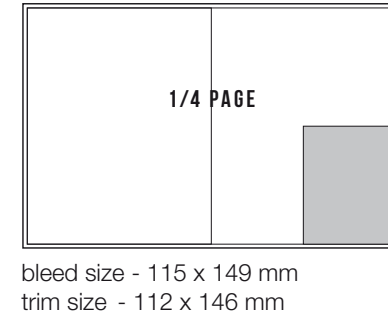
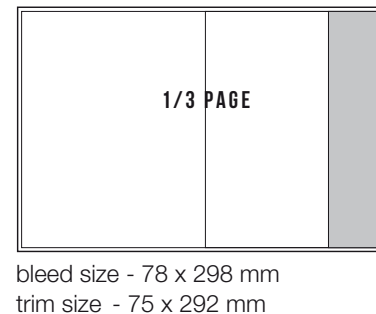
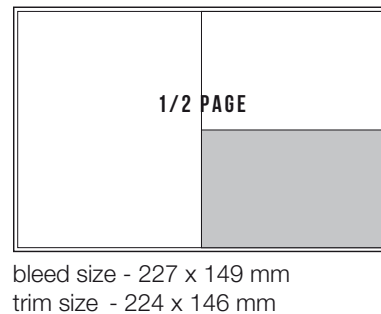
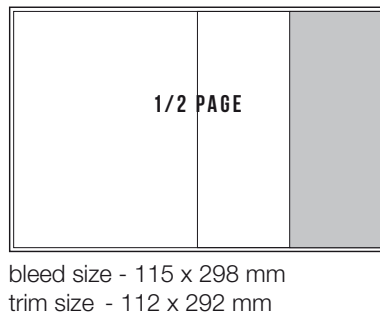
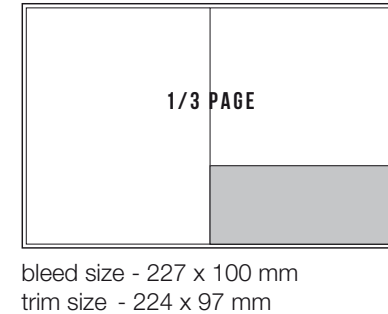
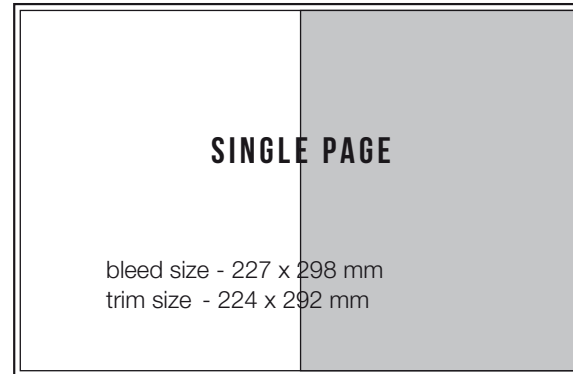
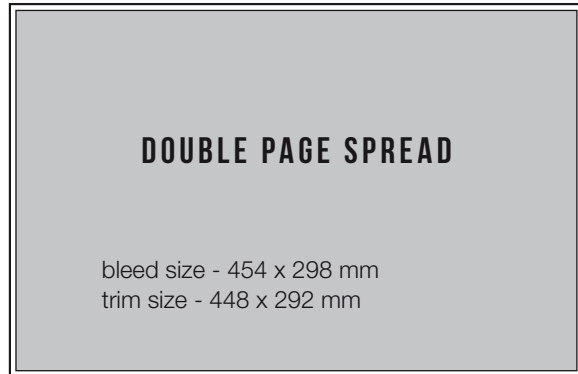

### production requirements

PDF - Press optimized, curves, CMYK  
EPS - curves, CMYK  
TIFF - 300 dpi, CMYK